



Produttore di ghiaccio con contenitore incorporato - Sistema a trafila
Produzione giornaliera fino a 105 kg

| | |
|----------------|------------|
| Hotel | ██████████ |
| Ristoranti | ██████████ |
| Fast food | ██████████ |
| Bar | ██████████ |
| Discoteche | ██████████ |
| Mercati ittici | ██████████ |
| Supermercati | ██████████ |
| Medicale & SPA | ██████████ |
| Industrie | ██████████ |

► **Position n°**



► **Features & Plus**

- Ghiaccio a tronchetti 91% dry
- 1L (acqua) = 1kg (ghiaccio) - solo A
- Carrozzeria AISI 304 Scotch Brite
- Classe Tropicale + 43° C
- Piedini acciaio inox regolabili
- Filtro Aria smontabile e pulibile
- Evaporatore in Acciaio AISI 304
- Condensazione aria o acqua
- Superfici interne arrotondate per pulizia
- Isolamento contenitore HCFC-Free
- Bacinella acqua sigillata antipolvere
- RoHS Free
- Sportello isolato con apertura a scomparsa
- Funzionamento elettromeccanico
- Interruttore ON/OFF
- Carico automatico dell'acqua
- Voltaggio standard e voltaggi speciali
- HFC Free



Carrozzeria AISI 304 Scotch Brite



Filtro Aria smontabile e pulibile



Evaporatore in Acciaio AISI 304



Bacinella acqua sigillata antipolvere



Sportello isolato con apertura a scomparsa

► **Dimensione disponibile**

Disegno a scopo esclusivamente indicativo

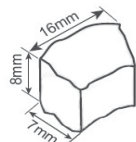

► **Prod. 24h**

| T. aria | T. acqua | | kg | lbs |
|---------|----------|-------|-------|-----|
| | 10° C | 50° F | | |
| 21° C | 70° F | 15° C | 60° F | 90 |
| | | | | 198 |

Garanzia 2 Anni
soggetta a limitazioni

► **Certificazioni disponibili per questo modello**



Intertek





Ice Pebbles

TB 852 HC



Produttore di ghiaccio con contenitore incorporato - Sistema a trafila
Produzione giornaliera fino a 105 kg

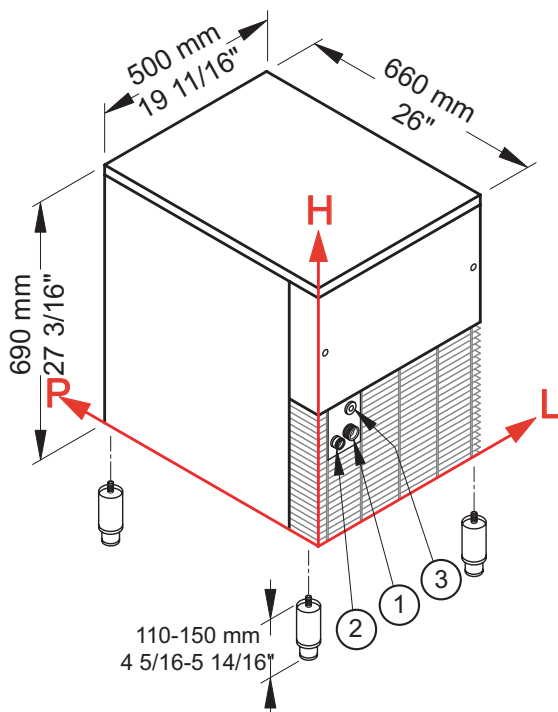

► Condizioni d'installazione

- Installazione: **Interna**

| | Min | Max |
|-------------------------|-----------------|-----------------|
| Temperatura ambiente | +10° C / +50° F | +43° C / 110° F |
| Temperatura acqua | +3° C / +37° F | +32° C / +90° F |
| Voltaggio | -10% | +10% |
| Pres. acqua in ingresso | 1bar (14 psi) | 6bar (84 psi) |

► Performance

| | Temperatura acqua | Temperatura acqua | | | | | |
|------------------|-------------------|-------------------|-------|---------|-------|---------|-------|
| | | 7° C | 45° F | 15° C | 60° F | 21° C | 70° F |
| Temperatura aria | 10° C | 105 kg | | | | | |
| | 50° F | 231 lbs | | | | | |
| | 21° C | | 90 kg | | | | |
| | 70° F | | | 198 lbs | | | |
| | 32° C | | | | 74 kg | | |
| | 90° F | | | | | 163 lbs | |

► Connessioni

Le misure sono riferite all'angolo del retro in basso a sinistra (L-H-Ø)

- ① Ingresso acqua: 99 mm / 3 14/16" - 158 mm / 6 4/16" - 3/4" ② Scarico acqua: 48 mm / 1 14/16" - 151 mm / 5 15/16" - 24 mm / 15/16"
③ Connessione elettrica: 87 mm / 3 7/16" - 230 mm / 9 1/16"

► Dati tecnici

| | | | |
|------------------------------|-------------------|-------------------------------|---------------------------------|
| Produzione in 24h | 90 kg / 198 lbs | Consumo d'acqua | A: 1 l/kg - 12,0 gal/100 lbs |
| Capacità contenitore, fino a | 20 kg / 44 lbs | | W: 7 l/kg - 84 gal/100 lbs |
| Condensazione | A - W | Dimensioni (L-P-H mm) | 500 - 660 - 690 |
| Dimensioni indicative pebble | 8 x 16 x 7 | (L-P-H in) | 19 11/16 - 26 - 27 3/16 |
| Refrigerante | R290 | Dimensioni imballo (L-P-H mm) | 550 - 720 - 880 |
| Voltaggio standard | 220-240 V ~ 50 Hz | (L-P-H in) | 21 10/16 - 28 6/16 - 34 10/16 |
| Potenza media assorbita | 440 W | Peso netto | 59 kg / 130 lbs |
| Fusibile | 10 A | Peso lordo | 67 kg / 148 lbs |
| Consumo elettrico | 13 kWh/100kg | Finitura | Acciaio inox 18/8, scotch brite |

Tutti i dati tecnici sono da considerarsi validi alle seguenti condizioni:
Temperatura ambiente +21° C
Temperatura acqua +15° C
Consumo elettrico a +32° C (Voltaggio standard)
Potenza media assorbita a +43° C (Voltaggio standard)

I modelli ed i dati riportati possono essere soggetti a modifiche senza alcun preavviso

Rev. 00 - Pubblicato Marzo 2021



www.bremaice.it
info@bremaicegroup.it

We are Brema

